

CIVILMART



Up-Flo™ Filter FLUIDISED MEDIA BED UP-FLOW FILTRATION SYSTEM



CIVILMART

Hydro
International 

Fluidised Media Bed Up-Flow Filtration System

The Civilmart Up-Flo™ Filter is the most efficient high-rate stormwater filtration technology available for the removal of sediments, nutrients, metals and hydrocarbons from stormwater runoff.

As the industry's only fluidized bed upflow filtration technology, the Up-Flo™ Filter provides a higher level of treatment, a higher rate of filtration, longer life of filter media and a longer maintenance cycle than other filter systems.

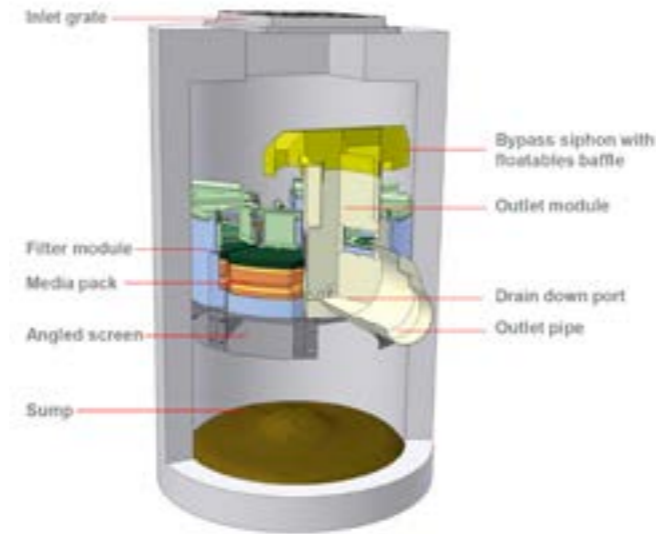

How It Works

During a storm event, stormwater enters the chamber via an inlet pipe or inlet grate and fills the chamber, as flow is directed up through the angled screen and filter modules. Flow is evenly distributed across the media for maximum treatment.

Gross debris and sediment settle out in the sump. Oil and floatables rise to the surface of the water.

Treated water flows out of the filter module to the outlet module and into the outlet pipe.

Excess flows are discharged to the outlet using a siphon bypass, which also acts as a floatables baffle, preventing the escape of oil and floatable trash.

To guard against pollutant leaching and filter media degradation between storm events, water drains out of the chamber through the filtered drain-down port as the storm subsides.

CPZ™ Mix

- Over 70% removal of metals, nutrients & TSS
- TSS removal down to 1 micron particle
- 1.6 l/s per module

Product Selection Table

UFF Model Type	Chamber Size	Number of Modules	Maximum Treatment Flow (L/s)	Peak Syphonic Bypass Flow (L/s)	Min Standard Headloss (mm)	Sump Storage Capacity (Litres)
Standard	DN1200	1 - 6	9.6	170	500	700
Small Vault	DN1800	7 - 8	12.8	225	500	1580
Medium Vault	DN2400	9 - 14	22.4	400	500	2800
Large Vault	DN2700	15 - 19	30.4	535	500	3550
Special	As required	>19	>30.4	>535	500	As designed

Filter Modules

Each filter module has a typical treatment flow rate of 1.6 L/sec.

Sizing And Design

The Civilmart Up-Flo™ Filter is sized to treat a specified runoff area or a design flow rate for a water quality design storm.

The number of modules is determined by the treatment objectives and the size of the runoff area. This is based on each individual filter module treatment flowrate.

The flexibility of the system allows effective design for sites with low hydraulic drops. Civilmart Water Quality's expert PAD engineering team can assist in designing a system that is right for each situation.

To allow easier access to the individual modules the design includes removeable lids that can be temporarily stacked adjacent to the inlet.

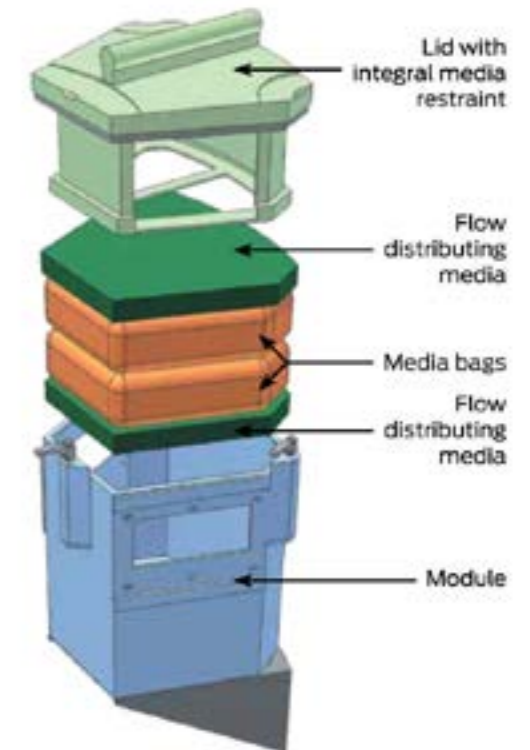

Design developed at the University of Alabama. Data is collected through extensive field testing by the University of Alabama. No chemical exhaustion of media after 12 months of field testing.



Installation

Installing a Civilmart Up-Flo™ Filter is as simple as installing a standard precast pit and connecting to the stormwater system.

Maintenance

Maintenance is simple, with easy access to the sump and replaceable media packs. A vacuum truck is used to remove sediment and other pollutants from the sump and the media packs are replaced manually. Unlike other filtration systems, no specialised heavy lifting equipment is needed.



CIVILMART Hydro International
civilmart.com.au



QLD

Civilmart Sunshine Coast	07 5493 3044
Civilmart Brisbane	07 3800 7855
Civilmart Gold Coast	07 5597 6966
Civilmart Toowoomba Tanks	07 4634 3860
Civilmart Stapylton	07 3807 4511
Civilmart CM Stapylton	07 3804 6622
Civilmart Rocla Rockhampton	07 4923 1500
Civilmart Rocla Cairns	07 4042 3400

NSW

Civilmart Sydney	02 9612 5800
Civilmart Central Coast	02 4355 6300
Civilmart Rocla Mittagong	02 4889 6000
Civilmart Rocla Grafton	02 6640 1800

VIC

Civilmart Melbourne	03 5491 8324
Civilmart Shepparton	03 5821 2810
Civilmart Shepparton Pipe	03 5821 3099
Civilmart Geelong	03 5274 1126
Civilmart Rocla Clayton	03 9549 4500
Civilmart Rocla Campbellfield	03 9292 0300
Civilmart Rocla Wodonga Poles	02 6055 7350
Civilmart Rocla Wodonga Precast	02 6055 7300

SA

Civilmart Adelaide	08 8209 3093
Civilmart Rocla Adelaide	08 7285 1900